



[3000 Series Time Delay Relays and Measuring Relays]

- Time Delay Relays
 - DIN Rail Mounted
 - Wall Socket Version
- Measuring Relays

Welcome

Dear Reader,
Dear Client and Partner,

Welcome to our brochure for the Series 3000
Measuring and Time Delay Relays of SCHRACK
ENERGIETECHNIK GmbH.

This catalogue presents our various measuring and
time delay relays. In addition, we would like to draw
your attention, as an expert with high quality
requirements, to the multitude of combination options
using our relevant accessory products.

Your satisfaction is our most important ambition.
It is therefore self-evident that we also provide relevant
consulting and support by phone or on-site, by way
of our sales force, which comprises qualified electricians
and electrical engineering technicians.
Being your reliable partner in power engineering we
welcome your challenge. Take us by our word!

Looking forward to your contact,
Yours Sincerely,

SCHRACK ENERGIETECHNIK GmbH

Content	Page	Content	Page
Time Delay Relays	1 - 17	Measuring Relays	18 - 31
General Information	1	General Information	18
ZR3MF011 Multi-Function Relay	2 - 3	UR3T3011 Voltage Monitor Relay with Adjustable Time Range	18 - 19
ZR3MF012 Multi-Function Relay	4 - 5	UR3U3011 3-Phase Voltage Monitor Relay with Adjustable Voltage Range 1 ph.	20 - 21
ZR3ER011 Dual Function Relay	6 - 7	UR3U1011 Single Phase Voltage Monitor Relay	22 - 23
ZR3R0011 Single Function Relay	8 - 9	UR3R1011 Thermal Relay	24 - 25
ZR3E0011 Single Function Relay	10 - 11	UR3L1011 Liquid Level Monitor Relay	26 - 27
ZR3B0011 Single Function Relay	12 - 13	UR3I1011 Current Monitor Relay	28 - 29
ZR3SD011 Wye Delta Relay	14 - 15	UR3P3011 Phase Monitor Relay	30 - 31
Multi-Function Time Delay Relay and Dimmer Switch for Wall Sockets	16 - 17		

[In General]

Protection Class:	Housing: IP 40/Terminals: IP 20
Terminal Cross Section:	With Ferrules: 2 x 1.5 mm ² ; 2 x 2.5 mm ² Without Ferrules: 2 x 1.5 mm ² ; 2 x 2.5 mm ²
Output Indicator:	Yellow LED
Supply Indicator:	Green LED
Standard:	IEC/EN 61812-1
Ambient Operating Temperature Range:	-20 °C to +60 °C
Storage Temperature Range:	-30 °C to +70 °C

[Mounting of Units on the DIN Mounting Rail]

EN 60715 compliant snap fasteners enable simple snap-on installation and removal of the units to and from the DIN Mounting Rail.

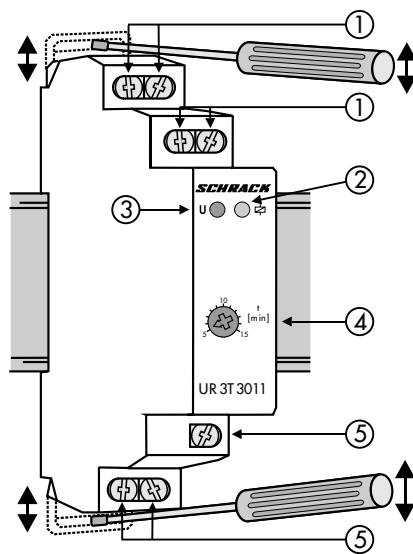

- ① Supply Voltage Terminals
- ② Output Indicator (Yellow)
- ③ Supply Voltage Indicator (Green)
- ④ Time Delay Setting
- ⑤ Output Contact

[General Characteristics of Time Delay Relays]

The following applies in general:

- 1 TE \triangleq 17.5 mm
- Supply Voltage = 12-240 V AC/DC
- 1 Changeover Contact 16 A, 250 V, 4000 VA
- 2 Make Contacts 8 A, 250 V, 2000 VA
- State of the Art Technology

Time Delay Relays

[ZR3MF011 Multi-Function Relay]



ZR3MF011

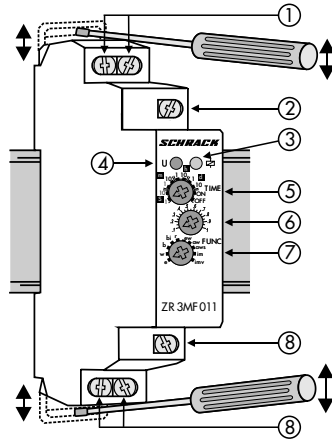

- ① Supply Terminals
- ② Control Input „START“
- ③ Output Indicator
- ④ Supply Voltage Indicator
- ⑤ Coarse Timer Setting
- ⑥ Precision Timer Setting
- ⑦ Function Selection
- ⑧ Output Contact

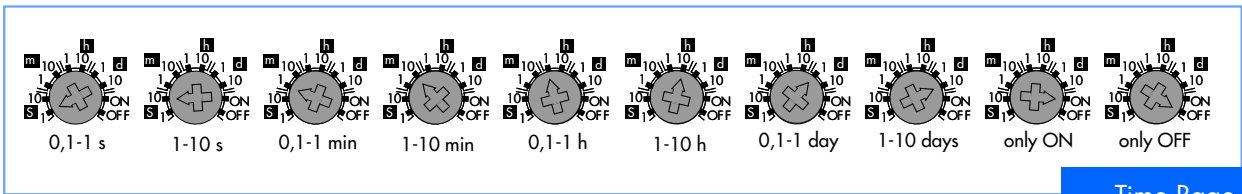

Time Range

Functions:

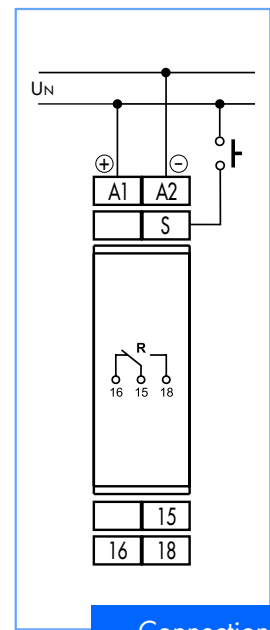
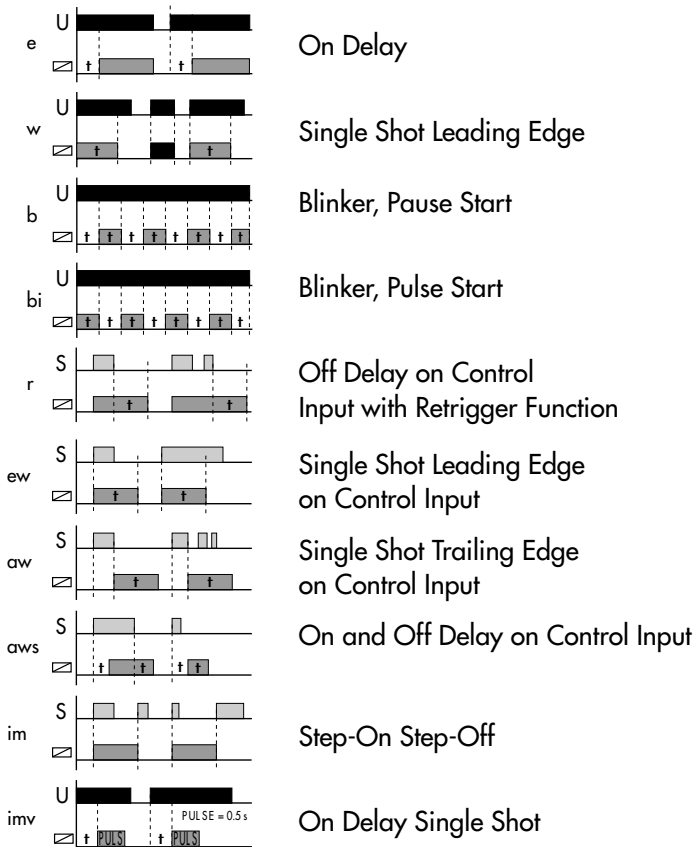

Connection Diagram

Time Delay Relays

Technical Specifications

Description	ZR3MF011
Function	Multi-Function Relay with 10 Functions
Supply Terminals	A1 - A2
Supply Voltage	12/240 V AC/DC/(AC 50 - 60 Hz)
Power Consumption	AC 0.7 - 3 VA/DC 0.5 - 1.7 W
Supply Voltage Tolerance according to Standard (DIN)	- 15%; +10%
Time Range	0.1 s - 10 days
Timer Setting	Rotary Switch and Potentiometer
Time Deviation	5% - Mechanical Setting
Repeat Accuracy	0,2%
Temperature Stability	0,01 %/°C at 20 °C
Overvoltage Category	III.
Pollution Degree	2
Terminal Cross-Section with/without Ferrules	2 x 1.5 mm ² ; 2 x 2.5 mm ²
Dimensions	17.6 x 90 x 64 mm
Weight	76 g
Standards	IEC/EN 61812-1
Output	
Schrack Relay Type	RT314006
Number of Changeover Contacts	1
Rated Current/Duty Category	16 A/AC1
Max. Inrush Current	30 A/< 3 s/AC1
Max. Switching Capacity	4000 VA/AC1, 384 W/DC
Min. Permissible Load	DC 500 mW
Output Indicator	Yellow LED
Mechanical Life Expectancy	3 x 10 ⁷ operations
Electrical Life Expectancy at Rated Load	0.7 x 10 ⁵ operations
Control	Supply Voltage 12 - 240 V AC/DC
Control Voltage on Contact	12/240 V AC/DC
Power Consumption at Input	0.025 - 0.2 VA/0.1 - 0.7 W
Load Between S and A2	Yes
Connection of Glow Lamp on the Control Contact	Not possible
Control Terminals	A1-S
Triggering Time	min. 25 ms/up to 100 % ED
Reset Time	max. 150 ms
Surge Withstand	2.5 kV coil to contacts
Mounting Position	Any position

Time Delay Relays

[ZR3MF012 Multi-Function Relay]



ZR3MF012

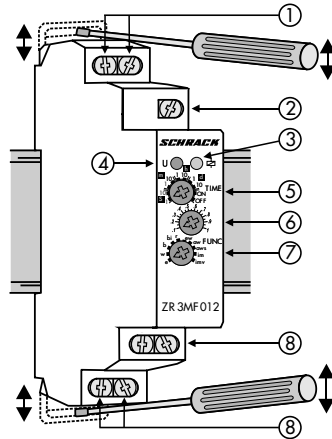

- ① Supply Terminals
- ② Control Input "START"
- ③ Output Indicator
- ④ Supply Voltage Indicator
- ⑤ Coarse Timer Setting
- ⑥ Precision Timer Setting
- ⑦ Function Selection
- ⑧ Output Contact

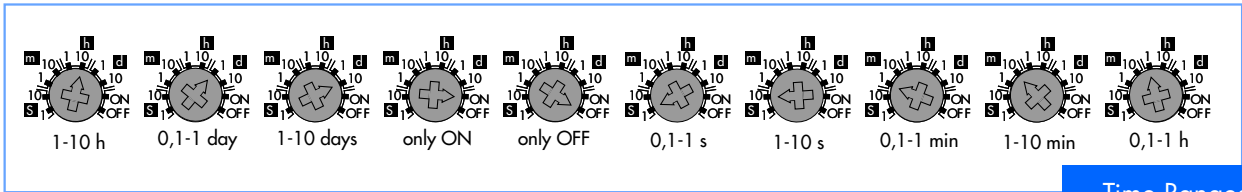

Time Ranges

Functions:

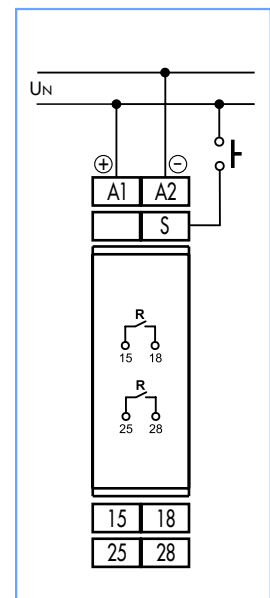
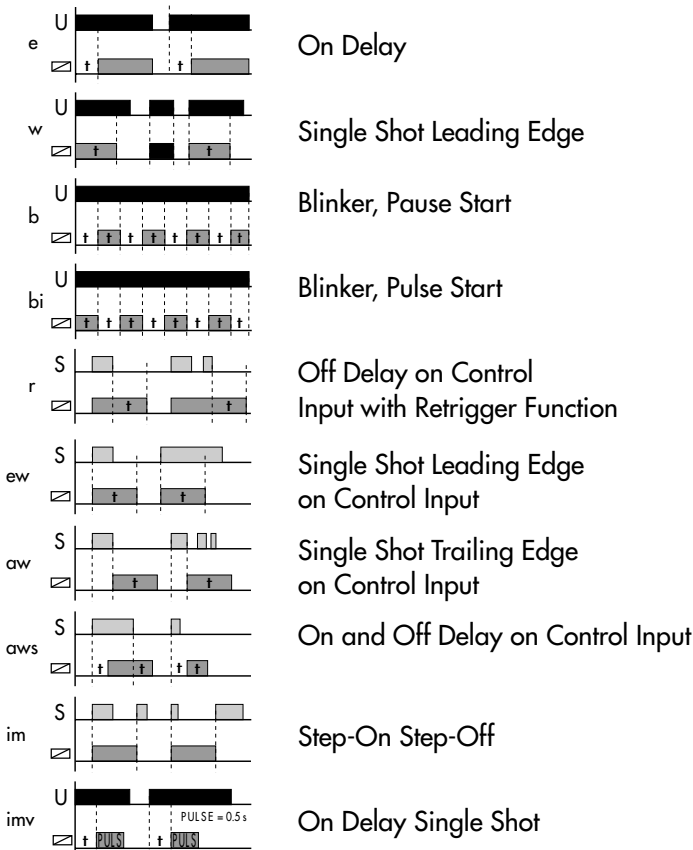

Connection Diagram

Parallel Load between A2 and S

Time Delay Relays

Technical Specifications

Description	ZR3MF012
Function	Multi-Function Relay with 10 Functions
Supply Terminals	A1 - A2
Supply Voltage	12/240 V AC/DC/(AC 50 - 60 Hz)
Power Consumption	AC 0.7 - 3 VA/DC 0.5 - 1.7 W
Supply Voltage Tolerance according to Standard (DIN)	- 15%; +10%
Time Range	0.1 s - 10 days
Timer Setting	Rotary Switch
Time Deviation	5% - Mechanical Setting
Repeat Accuracy	0,2%
Temperature Stability	0.01 %/°C at 20 °C
Overvoltage Category	III.
Pollution Degree	2
Terminal Cross-Section with/without Ferrules	2 x 1.5 mm ² ; 2 x 2.5 mm ²
Dimensions	17.6 x 90 x 64 mm
Weight	92 g
Standards	IEC/EN 61812-1
Output	
Schrack Relay Type	RT314006
Number of Changeover Contacts	2
Rated Current/Duty Category	8 A/AC1
Max. Inrush Current	10 A/< 3 s/AC1
Max. Switching Capacity	2000 VA/AC1, 384 W/DC
Min. Permissible Load	DC 500 mW
Output Indicator	Yellow LED
Mechanical Life Expectancy	3 x 10 ⁷ operations
Electrical Life Expectancy at Rated Load	0.7 x 10 ⁵ operations
Control	Supply Voltage 12 - 240 V AC/DC
Control Voltage on Contact	12/240 V AC/DC
Power Consumption at Input	0.025 - 0.2 VA/0.1 - 0.7 W
Load Between S and A2	Yes
Connection of Glow Lamp on the Control Contact	Not possible
Control Terminals	A1-S
Triggering Time	min. 25 ms/up to 100 % ED
Reset Time	max. 150 ms
Surge Withstand	2.5 kV coil to contacts
Mounting Position	Any position

Time Delay Relays

[ZR3ER011 Dual Function Relay]



ZR3ER011

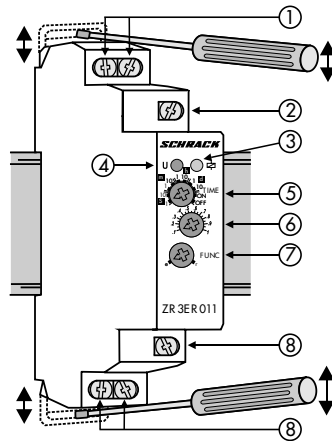

- ① Supply Terminals
- ② Control Input "START"
- ③ Output Indicator
- ④ Supply Voltage Indicator
- ⑤ Coarse Timer Setting
- ⑥ Precision Timer Setting
- ⑦ Function Selection
- ⑧ Output Contact

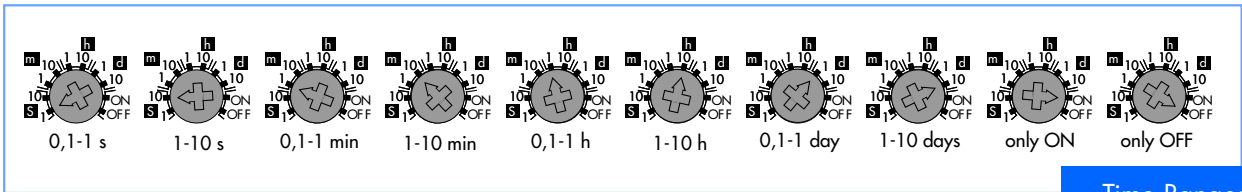

Time Ranges

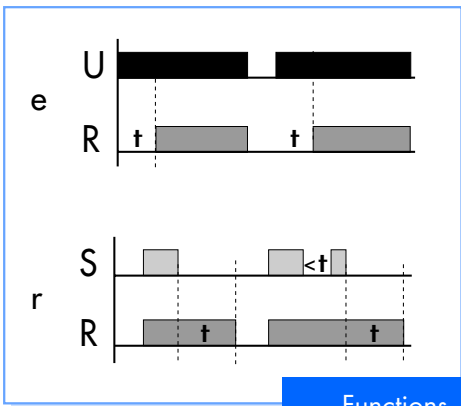

Functions

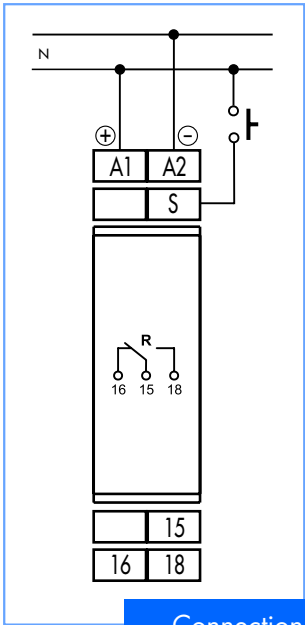

Connection Diagram

Hint

To avoid a current surge when simultaneously energizing several time delay relays, it is recommended that the relays be energized with different time lags!

Time Delay Relays

Technical Specifications

Description	ZR3ER011
Function	On Delay/Off Delay
Supply Terminals	A1 - A2
Supply Voltage	12/240 V AC/DC/(AC 50 - 60 Hz)
Power Consumption	AC 0.7 - 3 VA/DC 0.5 - 1.7 W
Supply Voltage Tolerance according to Standard (DIN)	- 15 %; +10 %
Time Range	0.1 s - 10 days
Timer Setting	Rotary Switch with Potentiometer
Time Deviation	5 % - Mechanical Setting
Repeat Accuracy	0.2 %
Temperature Stability	0.01 %/°C at 20 °C
Overvoltage Category	III.
Pollution Degree	2
Terminal Cross-Section with/without Ferrules	2 x 1.5 mm ² ; 2 x 2.5 mm ²
Dimensions	17.6 x 90 x 64 mm
Weight	76 g
Standards	IEC/EN 61812-1
Output	
Schrack Relay Type	RT314006
Number of Changeover Contacts	1
Rated Current/Duty Category	16 A/AC1
Max. Inrush Current	30 A/< 3 s/AC1
Max. Switching Capacity	4000 VA/AC1, 384 W/DC
Min. Permissible Load	DC 500 mW
Output Indicator	Yellow LED
Mechanical Life Expectancy	3 x 10 ⁷ operations
Electrical Life Expectancy at Rated Load	0.7 x 10 ⁵ operations
Control	Supply Voltage 12 - 240 V AC/DC
Control Voltage on Contact	12/240 V AC/DC
Power Consumption at Input	0.025 - 0.2 VA/0.1 - 0.7 W
Load Between S and A2	Yes
Connection of Glow Lamp on the Control Contact	Not possible
Control Terminals	A1-S
Triggering Time	min. 25 ms/bis 100 % ED
Reset Time	max. 150 ms
Surge Withstand	2.5 kV coil to contacts
Mounting Position	Any Position

Time Delay Relays

[ZR3R0011 Single Function Relay]

8



ZR3R0011

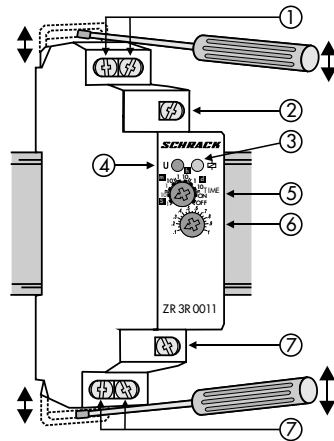

- ① Supply Terminals
- ② Control Input "START"
- ③ Output Indicator
- ④ Supply Voltage Indicator
- ⑤ Coarse Timer Setting
- ⑥ Precision Timer Setting
- ⑦ Output Contact

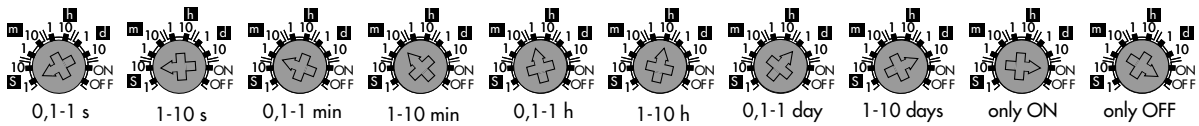

Time Ranges

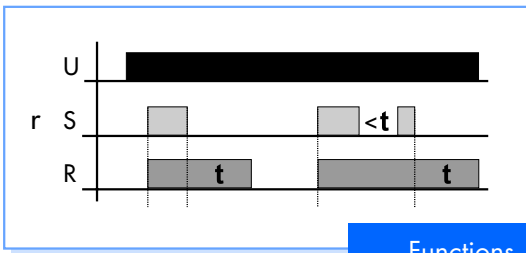

Functions

Off Delay on Control Input with Retrigger Function

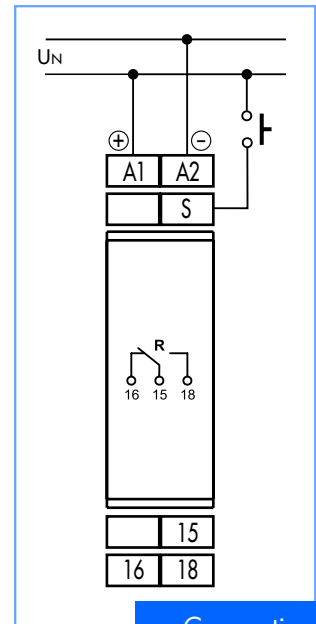

Connection Diagram

Hint Always select the right device for your application!

Technical Specifications

Description	ZR3R0011
Function	Off Delay
Supply Terminals	A1 - A2
Supply Voltage	12/240 V AC/DC/(AC 50 - 60 Hz)
Power Consumption	AC 0.7 - 3 VA/DC 0.5 - 1.7 W
Supply Voltage Tolerance according to Standard (DIN)	- 15 %; +10 %
Time Range	0.1 s - 10 days
Timer Setting	Rotary Switch and Potentiometer
Time Deviation	5 % - Mechanical Setting
Repeat Accuracy	0.2 %
Temperature Stability	0.01 %/°C at 20 °C
Overvoltage Category	III.
Pollution Degree	2
Terminal Cross-Section with/without Ferrules	2 x 1.5 mm ² ; 2 x 2.5 mm ²
Dimensions	17.6 x 90 x 64 mm
Weight	76 g
Standards	IEC/EN 61812-1
Output	
Schrack Relay Type	RT314006
Number of Changeover Contacts	1
Rated Current/Duty Category	16 A/AC1
Max. Inrush Current	30 A/< 3 s/ AC1
Max. Switching Capacity	4000 VA/AC1, 384 W/DC
Min. Permissible Load	DC 500 mW
Output Indicator	Yellow LED
Mechanical Life Expectancy	3 x 10 ⁷ operations
Electrical Life Expectancy at Rated Load	0.7 x 10 ⁵ operations
Control	Supply Voltage 12 - 240 V AC/DC
Control Voltage on Contact	12 - 240 V AC/DC
Power Consumption at Input	0.025 - 0.2 VA/0.1 - 0.7 W
Load Between S and A2	Yes
Connection of Glow Lamp on the Control Contact	Not possible
Control Terminals	A1-S
Triggering Time	min. 25 ms /up to 100 % ED
Reset Time	max. 150 ms
Surge Withstand	2.5 kV coil to contacts
Mounting Position	Any Position

Time Delay Relays

[ZR3E0011 Single Function Relay]

10



ZR3E0011

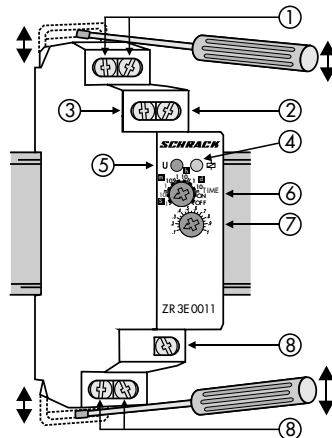

- ① Supply Terminals
- ② Control Input "START"
- ③ Function Selection Terminals
- ④ Output Indicator
- ⑤ Supply Voltage Indicator
- ⑥ Coarse Timer Setting
- ⑦ Precision Timer Setting
- ⑧ Output Contact

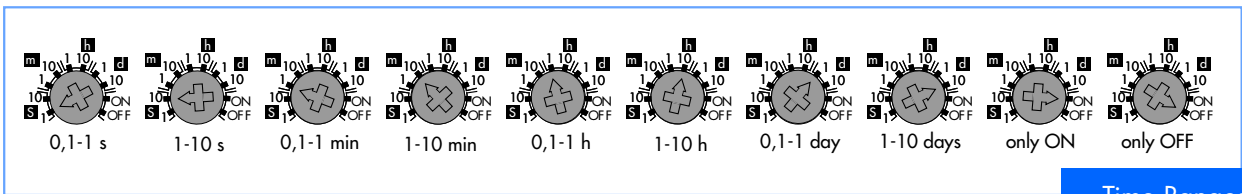

Time Ranges

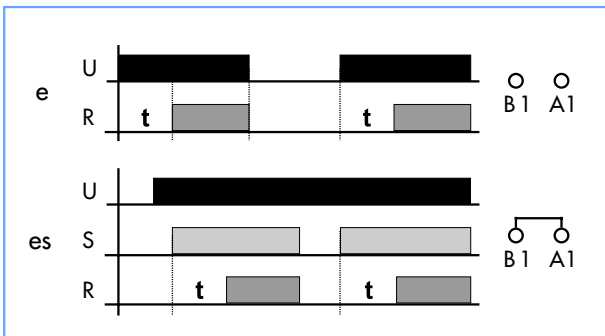

Functions

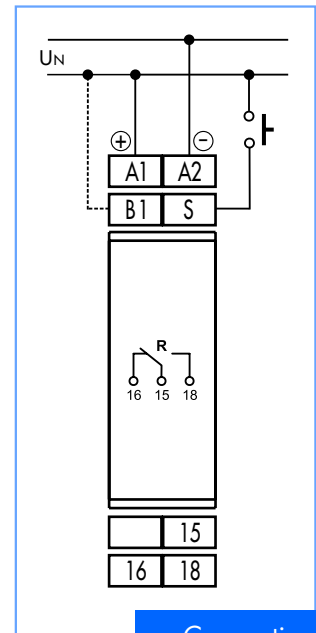

Connection Diagram

Hint

1. When selecting a new time range it is not necessary to de-energize and subsequently re-energize the supply voltage.
2. To change function control from supply voltage to control input S, connect terminals B1 and A1 with an external bridge.

Time Delay Relays

Technical Specifications

Description	ZR3E0011
Function	On Delay (2 nd function using external bridge between B1 and A1)
Supply Terminals	A1 - A2
Supply Voltage	12/240 V AC/DC/(AC 50 - 60 Hz)
Power Consumption	AC 0.7 - 3 VA/DC 0.5 - 1.7 W
Supply Voltage Tolerance according to Standard (DIN)	- 15 %; +10 %
Time Range	0.1 s - 10 days
Timer Setting	Rotary Switch with Potentiometer
Time Deviation	5 % - Mechanical Setting
Repeat Accuracy	0.2 %
Temperature Stability	0.01 %/°C at 20 °C
Overvoltage Category	III.
Pollution Degree	2
Terminal Cross-Section with/without Ferrules	2 x 1.5 mm ² ; 2 x 2.5 mm ²
Dimensions	17.6 x 90 x 64 mm
Weight	78 g
Standards	IEC/EN 61812-1
Output	
Schrack Relay Type	RT314006
Number of Changeover Contacts	2
Rated Current/Duty Category	8 A/AC1
Max. Inrush Current	30 A/< 3 s/AC1
Max. Switching Capacity	2000 VA/AC1, 192 W/DC
Min. Permissible Load	DC 500 mW
Output Indicator	Yellow LED
Mechanical Life Expectancy	3 x 10 ⁷ operations
Electrical Life Expectancy at Rated Load	0.7 x 10 ⁵ operations
Control	Supply Voltage 12 - 240 V AC/DC
Control Voltage on Contact	12/240 V AC/DC
Power Consumption at Input	0.025 - 0.2 VA/0.1 - 0.7 W
Load Between S and A2	Yes
Connection of Glow Lamp on the Control Contact	Not possible
Control Terminals	A1-S
Triggering Time	min. 25 ms/max. unlimited
Reset Time	min. 150ms/up to 100 % ED
Surge Withstand	2.5 kV coil to contacts
Mounting Position	Any Position

Time Delay Relays

[ZR3B0011 Single Function Relay]

12



ZR3B0011

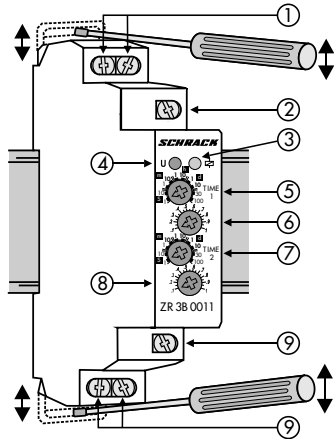

- ① Supply Terminals
- ② Function Selection Terminals
- ③ Supply Voltage Indicator
- ④ Output Indicator
- ⑤ Coarse Timer Setting PULSE
- ⑥ Precision Timer Setting PULSE
- ⑦ Coarse Timer Setting PAUSE
- ⑧ Precision Timer Setting PAUSE
- ⑨ Output Contact

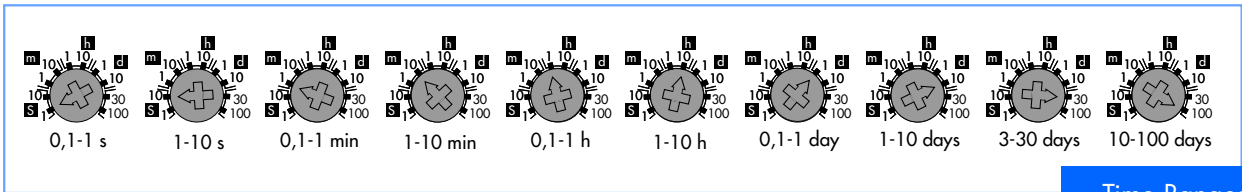

Time Ranges

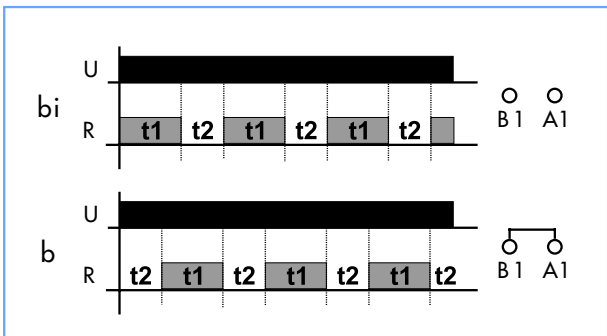

Functions

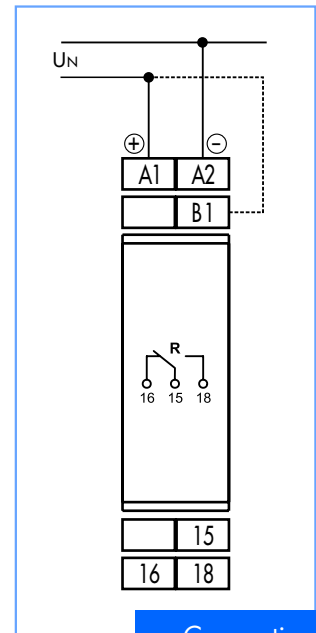

Connection Diagram

Hint

When selecting a new time range it is not necessary to de-energize and subsequently re-energize the supply voltage.

Technical Specifications

Description	ZR3B0011
Function	Repeat Cycle Timer (2 nd function using external bridge between B1 and A1)
Supply Terminals	A1 - A2
Supply Voltage	12/240 V AC/DC/(AC 50 - 60 Hz)
Power Consumption	AC 0.7 - 3 VA/DC 0.5 - 1.7 W
Supply Voltage Tolerance according to Standard (DIN)	+/- 15 %
Time Range	0.1 s - 100 days
Timer Setting	Rotary Switch and Potentiometer
Time Deviation	5 % - Mechanical Setting
Repeat Accuracy	0.2 %
Temperature Stability	0.01 %/°C at 20 °C
Overvoltage Category	III.
Pollution Degree	2
Terminal Cross-Section with/without Ferrules	2 x 1.5 mm ² ; 2 x 2.5 mm ²
Dimensions	17.6 x 90 x 64 mm
Weight	77 g
Standards	IEC/EN 61812-1
Output	
Schrack Relay Type	RT314006
Number of Changeover Contacts	1
Rated Current/Duty Category	16 A/AC1
Max. Inrush Current	30 A/< 3 s/AC1
Max. Switching Capacity	4000 VA/AC1, 384 W/DC
Min. Permissible Load	DC 500 mW
Output Indicator	Yellow LED
Mechanical Life Expectancy	3 x 10 ⁷ operations
Electrical Life Expectancy at Rated Load	0.7 x 10 ⁵ operations
Reset Time	min. 25 ms/up to 100 % ED
Surge Withstand	2.5 kV coil to contacts
Mounting Position	Any Position

Functional Description:

DIN Rail Mounted, 2 Timer Functions: 1. Repeat Cycle Timer Pulse Start, 2. Repeat Cycle Timer Pause Start
 Time switching: 0.1s - 100 Days, 10 Time Ranges, 12 - 240 V AC/DC

Time Delay Relays

[ZR3SD011 Wye-Delta Relay]

14



ZR3SD011

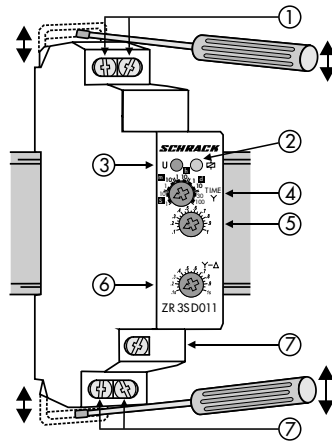

- ① Supply Terminals
- ② Output Indicator LED
- ③ Supply Voltage Indicator LED
- ④ Coarse Timer Setting t_1
- ⑤ Precision Timer Setting t_1
- ⑥ Precision Timer Setting t_2
- ⑦ Output Contact

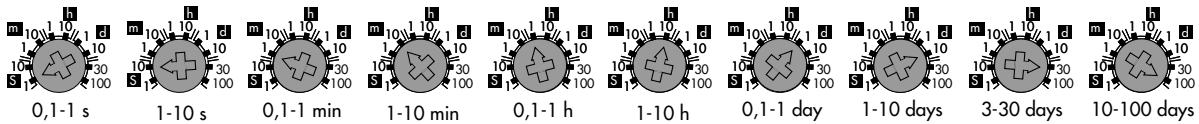

Time Ranges

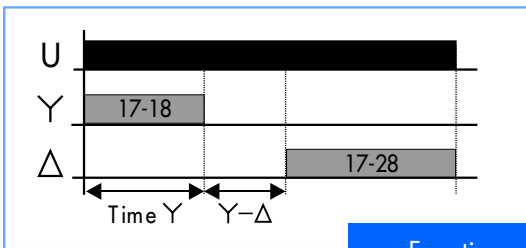

Functions

On Delay Wye-Delta

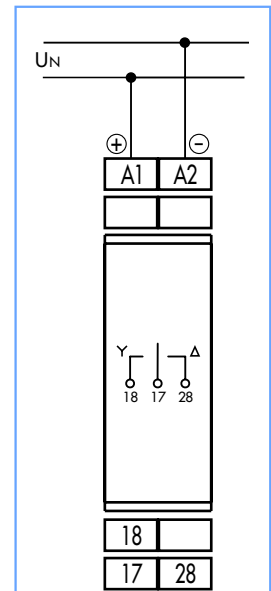

Connection Diagram

Hint

When selecting a new time range it is not necessary to de-energize and subsequently re-energize the supply voltage.

Technical Specifications

Description	ZR3SD011
Function	Wye-Delta
Supply Terminals	A1 - A2
Supply Voltage	12/240 V AC/DC/(AC 50 - 60 Hz)
Power Consumption	AC 0.7 - 3 VA/DC 0.5 - 1.7 W
Supply Voltage Tolerance according to Standard (DIN)	+/- 15 %
Time Range	0.1 s - 100 days
Timer Setting	Using a Potentiometer
Time Deviation	5 % - Mechanical Setting
Repeat Accuracy	0.2 %
Temperature Stability	0.01 %/°C at 20 °C
Overvoltage Category	III.
Pollution Degree	2
Terminal Cross-Section with/without Ferrules	2 x 1.5 mm ² ; 2 x 2.5 mm ²
Dimensions	17.6 x 90 x 64 mm
Weight	93 g
Standards	IEC/EN 61812-1
Output	
Schrack Relay Type	RT314006
Number of Changeover Contacts	1
Rated Current/Duty Category	16 A/AC1
Max. Inrush Current	30 A/< 3 s/AC1
Max. Switching Capacity	4000 VA/AC1, 384 W/DC
Min. Permissible Load	DC 500 mW
Output Indicator	Yellow LED
Mechanical Life Expectancy	3 x 10 ⁷ operations
Electrical Life Expectancy at Rated Load	0.7 x 10 ⁵ operations
Reset Time	max. 150 ms
Surge Withstand	2.5 kV coil to contacts
Mounting Position	Any Position

Functional Description:

DIN Rail Mounted, 1 Timer Function, t1 Time (Wye): 0.1 s - 100 days, 10 Time Ranges
t2 Time (delay): 0.1 s - 1 s, UNI-Voltage 12 - 240 V AC/DC

[Multi-Function Time Delay Relay and Dimmer Switch for Wall Sockets]

16



Wall Socket Version

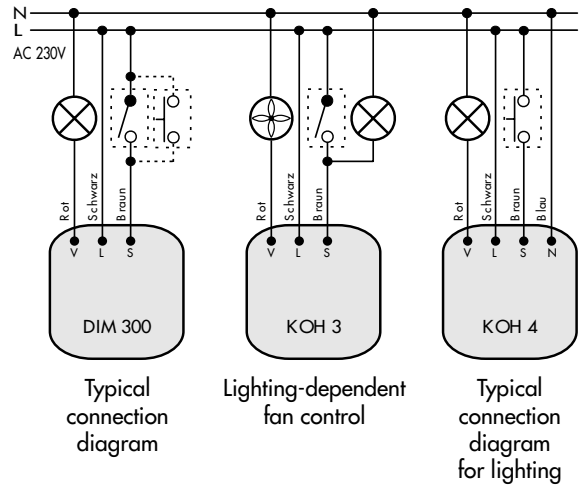

Typical connection diagram

Lighting-dependent fan control

Typical connection diagram for lighting

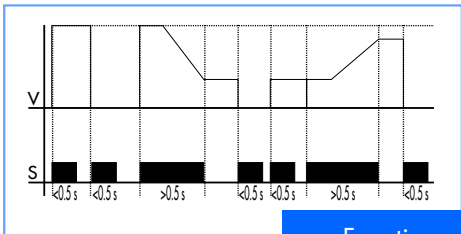

Functions

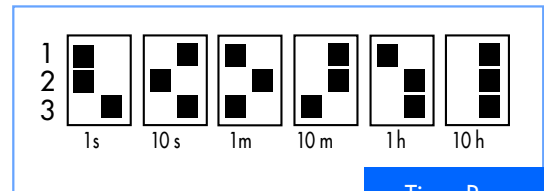

Time Ranges

A short push turns the lighting on and off.
A longer push ($> 0.5 s$) allows continuous brightness setting (min-max-min).
At turn off the brightness level is memorized and is automatically re-set at subsequent turn on.

Coarse Timer Setting:

Select from the above combinations for DIP-Switches 1-2-3 for time ranges from 1 s to 10 hours.

Precision Timer Setting:

Use a Potentiometer.



ew – Single Shot Leading Edge
Output is energized when the switch is turned on, regardless of the duration of the push.



r – Off Delay
Timer starts only when switch is turned off, output is immediately energized when switch is turned on.

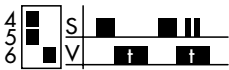

aw – Single Shot Trailing Edge
Output is energized only when the switch is turned off.



b – Blinker
Output blinks in regular intervals.

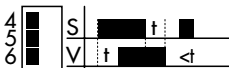

arv – Pulse Shift
On Delay when the switch is turned on and Off Delay when the switch is turned off.

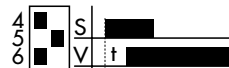

av – On Delay
Output stays energized until switch is turned off.

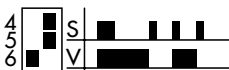

im – Step-On Step-Off
Single push energizes, subsequent push de-energizes the output.

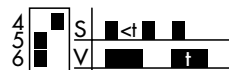

Step-On Step-Off with Delay
Single push energizes, subsequent push de-energizes the output.

Technical Specifications

	KOH 3	KOH 4	DIM 300
Order code	BZ326327	BZ326328	BZ326326
Description	Time Delay/Pulse Relay		Dimmer
Number of Functions	8		1
Terminals	3-pole without Neutral	4-pole with Neutral	3-pole without Neutral
Supply Voltage	230 V AC/50 - 60 Hz, Tolerance +/-15 % according to Standard (DIN)		
Power Consumption	0.5/4 VA	4 VA	3 VA
Output – Resistive Load	10 - 200 VA	0 - 200 VA	10 - 300 VA
Inductive Load	12 - 100 VA	0 - 100 VA	10 - 150 VA
Time Deviation	+/- 10 % of the Range		
Repeat Accuracy	+/- 1 % of the Range		
Glow Lamp in the Pushbutton	Yes, Max. No. 10		
Maximum Current on Control Input "S"	3 mA		
Triggering Time	min. 15 - 150 ms according to the time setting/up to 100 % ED		
Fuse	F 1 A/250 V		F 1.6 A/250 V
Reset Time	15 - 150 ms according to time setting		
Design	Conductor: CY, Cross-Section: 0.55 mm ² , Length: 90 mm		
Ambient Operating Temperature	Range 0 - 50 °C		
Dimensions	48 x 48 x 12 mm		
Weight	29 g	31 g	38 g
Standards	VDE 0110	VDE 0435	IEC664-1

[Measuring Relays In General]

Protection Class: Housing: IP 40/Terminals: IP 20
Terminal Cross Section: With Ferrules: 2 x 1.5 mm²; 2 x 2.5 mm²
 Without Ferrules: 2 x 1.5 mm²; 2 x 2.5 mm²
Ambient Operating Temperature Range: -20 °C to +55 °C
Storage Temperature Range: -30 °C to +70 °C

18

[UR3T3011 Voltage Monitor Relay with Adjustable Time Range]



UR3T3011

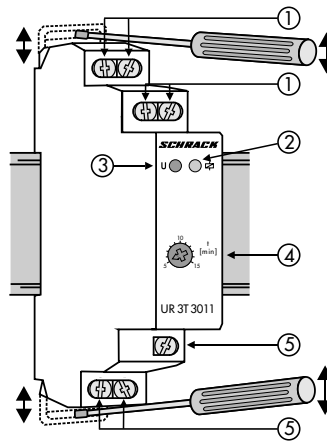

- ① Supply Voltage Terminals
- ② Output Indicator LED
- ③ Supply Voltage Indicator LED
- ④ Effective Range Setting
- ⑤ Output Contact

Function

This relay allows voltage monitoring in 3-phase networks vis-à-vis the Neutral. If the supply voltage is OK the green LED is lit. If the voltage in one or more of the phases drops below the switching threshold of 165 V, the relay drops out immediately and the yellow LED is extinguished. In case of supply voltage failure (Phase L1), the green LED is also extinguished. If the voltage remains stable above 165 V + 5% (hysteresis) in all phases for longer than the selected response delay, the relay output switches to its operational position and the yellow LED is lit. If only a single phase is being monitored, the terminals L1, L2 and L3 must be bundled together.

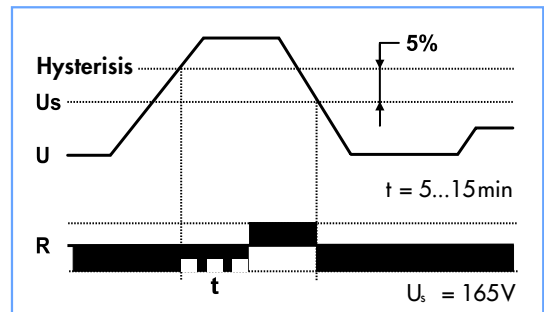

Functions

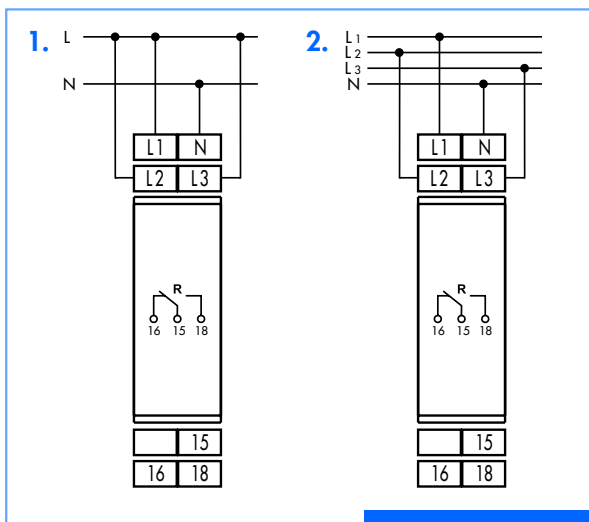

Connecting Diagram

1. Single Phase Connection.
2. 3-Phase Connection.

Optical Output Indicator LED

- Green is lit:** Supply voltage OK (L1-N)
Green is not lit: Supply voltage failure (L1-N)
Yellow is lit: The voltage in the phases (L1, L2, L3 vis-à-vis the Neutral) is greater than the drop out level (connects 15 and 18)
Yellow is not lit: The voltage in one of the phases is below the drop out level (connects 15 and 16)

Technische Specifications

Description	UR3T3011
Supply Terminals	L1, N
Supply Voltage	230 V AC; 50 Hz
Power Consumption	Max. 17 VA
Supply Voltage Tolerance according to Standard (DIN)	+/- 15%
Monitored Terminals	L1, L2, L3, N
Monitored Voltage	3 x 400 V/230 V + N
Max. Monitored Voltage (vis-à-vis Neutral)	276 V AC
Drop Out Level (fixed)	165 V AC
Hysteresis	Fixed 5%
Time Delay T	Adjustable between 5 - 15 min.
Overvoltage Category	III.
Pollution Degree	2
Terminal Cross-Section with/without Ferrules	2 x 1.5 mm ² ; 2 x 2.5 mm ²
Dimensions	17.6 x 90 x 64 mm
Weight	73 g
Standards	IEC/EN 60255-6
Output	
Schrack Relay Type	RT314024
Number of Changeover Contacts	1
Rated Current/Duty Category	16 A/AC1
Max. Inrush Current	30 A/< 3 s/AC1
Max. Switching Capacity	4000 VA/AC1, 384 W/DC
Min. Permissible Load	DC 500 mW
Output Indicator	Yellow LED
Mechanical Life Expectancy	3 x 10 ⁷ operations
Electrical Life Expectancy at Rated Load	0.7 x 10 ⁵ operations
Surge Withstand	2.5 kV coil to contacts
Mounting Position	Any Position

[UR3U3011 3-Phase Voltage Monitor Relay with Adjustable Voltage Range]

20



UR3U3011

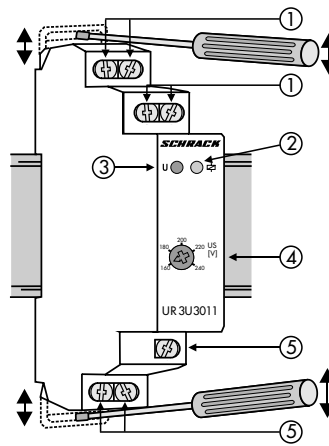

- ① Supply Voltage Terminals
- ② Output Indicator
- ③ Supply Voltage Indicator
- ④ Setting of U_s (Drop Out Level)
- ⑤ Output Contact

Funktion

If the supply voltage is OK, the green LED is lit. If the voltage in all 3 phases exceeds the drop out level setting (+5% hysteresis), the relay switches into its operational position (connecting 11 and 14) and the yellow LED is lit. The drop out level is adjustable between 160 - 240 V.

The hysteresis is set to a fixed 5% of the measured value. If voltage in any of the phases drops below the selected drop out level, the output relay drops out and the yellow LED is extinguished. Upon phase loss on L1 the green LED is also extinguished. This relay is specified for undervoltage or phase loss monitoring in 3-phase or single-phase networks.

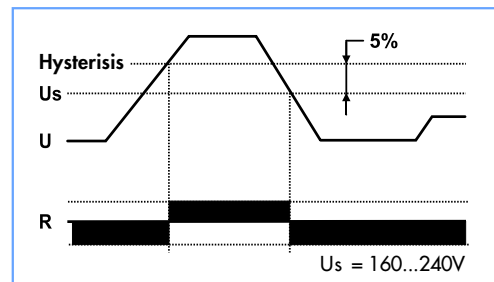

Functions

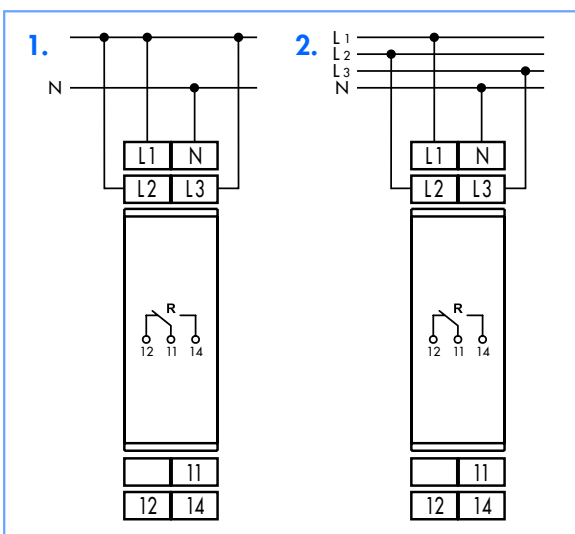

Connecting Diagram

Description

This relay can monitor 3 types of systems (24 V AC, 24 V DC, 230 V AC) for overstepping of a selected voltage level.

Output Contact: 1 x Changeover Contact 16 A.

1. Single Phase Connection.
2. 3-Phase Connection.

Optical Output Indicator LED

- Green is lit:** Supply voltage OK (L1-N)
Green is not lit: Supply voltage failure (L1-N)
Yellow is lit: The voltage in the phases (L1, L2, L3 vis-à-vis the Neutral) is greater than the switching level (disconnects 11 and 14)
Yellow is not lit: The voltage in one of the phases is below the drop out level (connects 11 and 14)

Technical Specifications

Description	UR3U3011
Supply Terminals	L1, N
Supply Voltage	AC 230 V; 50 Hz
Power Consumption	Max. 16 VA
Supply Voltage Tolerance according to Standard (DIN)	+/-15%
Supply Indicator	Green LED
Monitored Terminals	L1, L2, L3, N
Monitored Voltage	3 x 400 V/230 V + N
Max. Monitored Voltage (vis-à-vis Neutral)	276 V AC
Drop Out Level (adjustable)	160 - 240 V AC
Hysteresis	Fixed 5%
Overvoltage Category	III.
Pollution Degree	2
Terminal Cross-Section with/without Ferrules	2 x 1,5 mm ² ; 2 x 2,5 mm ²
Dimensions	17,6 x 90 x 64 mm
Weight	73 g
Standards	IEC/EN 60255-6
Output	
Schrack Relay Type	RT314024
Number of Changeover Contacts	1
Rated Current/Duty Category	16 A/AC1
Max. Inrush Current	30 A/< 3 s/AC1
Max. Switching Capacity	4000 VA/AC1, 384 W/DC
Min. Permissible Load	DC 500 mW
Output Indicator	Yellow LED
Mechanical Life Expectancy	3 x 10 ⁷ operations
Electrical Life Expectancy at Rated Load	0.7 x 10 ⁵ operations
Surge Withstand	2.5 kV coil to contacts
Mounting Position	Any Position

[UR3U1011 Single Phase Voltage Monitor Relay]

22



UR3U1011

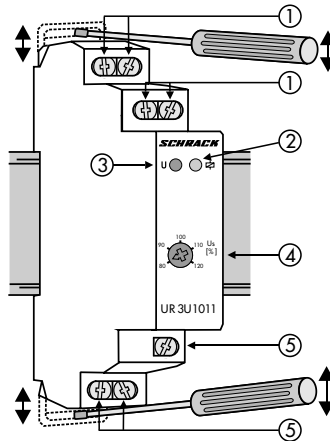

- ① Supply Voltage Terminals
- ② Output Indicator
- ③ Supply Voltage Indicator
- ④ Setting of U_s (Drop Out Level)
- ⑤ Setting of I_s (Pick Up Level)
- ⑥ Output Contact

Function

This relay can monitor 3 types of systems (24 V AC, 24 V DC, 230 V AC) for overstepping of a selected voltage level. The pick-up level (effective range) is adjustable between 80-120 % of the rated voltage using a potentiometer. If the supply voltage is OK, the green LED is lit. If the selected pick-up level is exceeded, the yellow LED is lit, and the relay switches (connects 11 and 14). If the supply voltage falls below the drop out level, the yellow LED is extinguished and the relay pulls down (connects 11 and 12). The hysteresis is set to a fixed 10%.

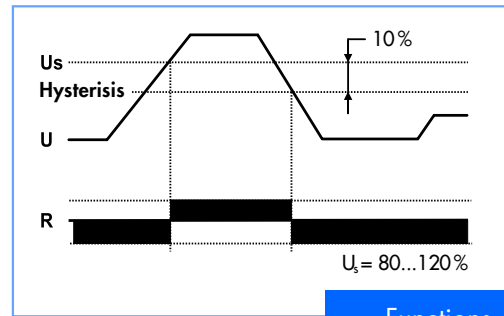

Functions

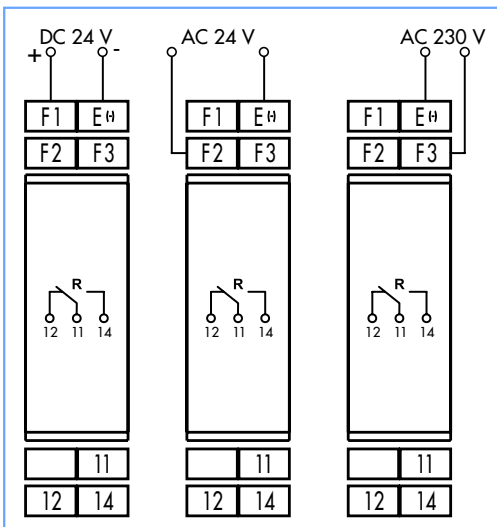

Connecting Diagram

Description

This relay can monitor 3 types of systems (24 V AC, 24 V DC, 230 V AC) for overstepping of a selected voltage level.

Output Contact: 1 x Changeover Contact 16 A.

Optical Output Indicator LED

- Green is lit:** Supply voltage OK
- Green is not lit:** Supply voltage failure or wrong polarity
- Yellow is lit:** The pick up level is exceeded, contacts 11 and 14 are connected
- Yellow is not lit:** Voltage has fallen below the drop out level, contacts 11 and 12 are connected

Technical Specifications

Description	UR3U1011
Supply Terminals	F1, F2, F3, E (-)
Rated Voltage/Maximum Voltage (F1-E)	24 V/DC Max. 32 V/DC
Power Consumption	Max. 1 W
Rated Voltage/Maximum Voltage (F2-E)	24 V/AC Max. 30 V/AC 50 Hz
Power Consumption	Max. 1,5 W
Rated Voltage/Maximum Voltage (F3-E)	230 V/AC Max. 276 V/AC 50 Hz
Power Consumption	Max. 8 W
Setting Accuracy	5 % - Mechanical Setting
Repeat Accuracy	1 %
Supply Indicator	Green LED
Drop Out Level (adjustable)	80 - 120 % of the Rated Voltage
Hysteresis	Fixed 10 %
Overvoltage Category	III.
Pollution Degree	2
Terminal Cross-Section with/without Ferrules	2 x 1.5 mm ² ; 2 x 2.5 mm ²
Dimensions	17.6 x 90 x 64 mm
Weight	72 g
Standards	IEC/EN 60255-6
Output	
Schrack Relay Type	RT314024
Number of Changeover Contacts	1
Rated Current/Duty Category	16 A/AC1
Max. Inrush Current	30 A/< 3 s/AC1
Max. Switching Capacity	4000 VA/AC1, 384 W/DC
Min. Permissible Load	DC 500 mW
Output Indicator	Yellow LED
Mechanical Life Expectancy	3 x 10 ⁷ operations
Electrical Life Expectancy at Rated Load	0.7 x 10 ⁵ operations
Surge Withstand	2.5 kV coil to contacts
Mounting Position	Any Position

[UR3R1011 Thermal Relay]

24



UR3R1011

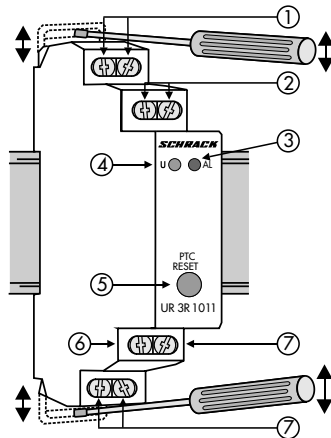

- ① Supply Voltage Terminals
- ② Sensor Connection Terminals
- ③ Output Indicator
- ④ Supply Voltage Indicator
- ⑤ RESET Button
- ⑥ Input for External RESET
- ⑦ Output Contact

Function

This relay is used to monitor PTC Temperature Sensors (connected to T1 and T2) to protect motors against overheating. If the auxiliary supply is on, the function indicator is lit in green. If the total resistance is less than 1.8 kΩ (this approximately represents the normal temperature of a motor), the output relay is energized and the green LED is lit. If the total resistance of the measuring element exceeds 3.3 kΩ, a failure condition is assumed, the output relay is de-energized and the red LED indicator is lit. If the motor subsequently reaches its normal temperature, and if the failure condition is cancelled using the Reset Button, the monitoring relay is again energized and the red function indicator is extinguished. The relay has one Input, R1 (external Reset). By interconnecting R1 to T1 the motor will also restart (after reaching its normal temperature) without activation of the Reset Button (Auto Reset Function).

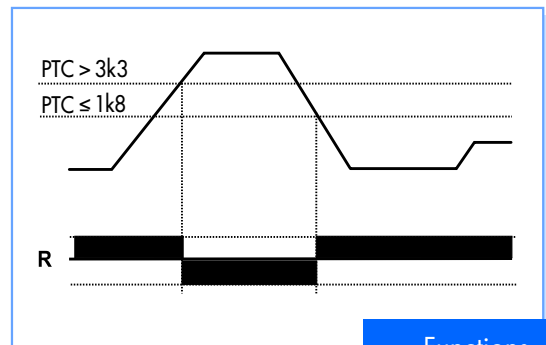

Functions

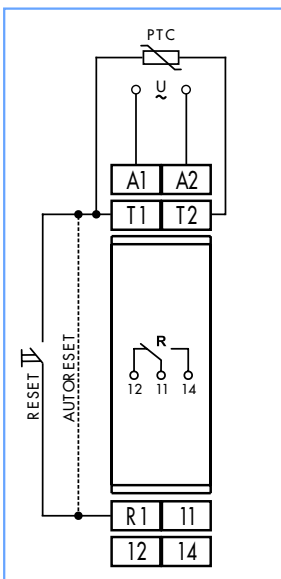

Connecting Diagram

Description

In the temperature range of the PTC Thermistor there are fix selected switching ranges, the PTC sensor is built into the winding, latching function.

Optical Output Indicator LED

Green is lit:	Supply voltage OK
Green is not lit:	Supply voltage failure
Red is lit:	PTC total resistance < 1.8 kΩ "Normal Temperature" (terminals 11 and 14 are connected)
Red is not lit:	PTC total resistance > 3.3 kΩ "ALARM Temperature" (terminals 11 and 12 are connected)
Operating Elements:	RESET-Button

Technical Specifications

Description	UR3R1011
Function	Temperature Control of the Motor Winding
Supply Terminals	A1 - A2
Supply Voltage	230 V AC; 50 Hz
Power Consumption	2 VA
Supply Voltage Tolerance according to Standard (DIN)	+/- 15 %
Measuring Circuit and Sensor	PTC (Part of the Motor)
Measuring Terminals	T1 - T2
Sensor Resistance – OK Max.	≤ 1.8 kΩ
Sensor Resistance – ALARM	≥ 3.1 kΩ
Hysteresis	+/- 10 %
Accuracy	
Repeat Accuracy	+/- 2 %
Switching Difference	+/- 5 %
Temperature Stability	< 0,2 %/°C
Overvoltage Category	III.
Pollution Degree	2
Terminal cross-section with/without Ferrules	2 x 1.5 mm ² ; 2 x 2.5 mm ²
Dimensions	17.6 x 90 x 64 mm
Weight	72 g
Standards	IEC/EN 60255-6
Output	
Schrack Relay Type	RT314024
Number of Changeover Contacts	1
Rated Current/Duty Category	16 A/AC1
Max. Inrush Current	30 A/< 3 s/AC1
Max. Switching Capacity	4000 VA/AC1, 384 W/24 VC DC
Min. Permissible Load	DC 500 mW
Output Indicator	Red LED
Mechanical Life Expectancy	3 x 10 ⁷ operations
Electrical Life Expectancy at Rated Load	0.7 x 10 ⁵ operations
Surge Withstand	2.5 kV coil to contacts
Mounting Position	Any Position

[UR3L1011 Liquid Level Monitor Relay]

26



UR3L1011

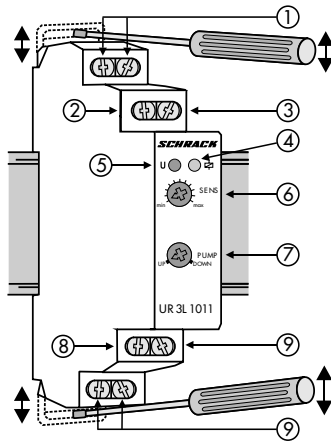

- ① Supply Voltage Terminals
- ② Upper Probe Terminal
- ③ Lower Probe Terminal
- ④ Output Indicator
- ⑤ Supply Voltage Indicator
- ⑥ Sensitivity Selection
- ⑦ Function Selection
- ⑧ Conductor Terminal for Both Probes
- ⑨ Output Contact

Function

This relay is specified to monitor the fill level of electroconductive liquids with a choice of two functions: **Pump Down** or **Pump Up**. To prevent liquid polarization and increased copper oxidation, the measuring uses alternating current. Measuring takes place using 3 probes: **E1** – Upper Level, **E2** – Lower Level and **E3** – Common Probe. If the liquid container is made of an electroconductive material, then the container itself can serve as the common probe and **E3** is not needed. In such cases probe **E3** is to be connected to the ground wire of the supply system (PE). In order to prevent unwanted switching (due to probe contamination, moisture, etc.) the liquid resistance can be set between 5 - 100 kΩ. The switching of the output has a fix delay setting of 5 s.

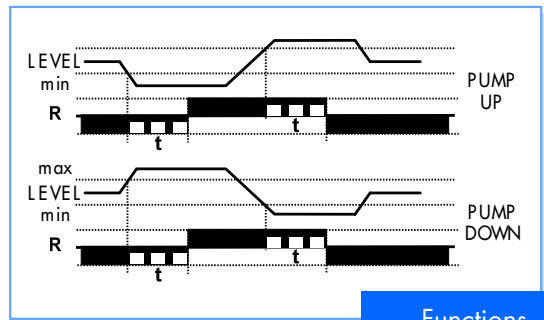

Functions

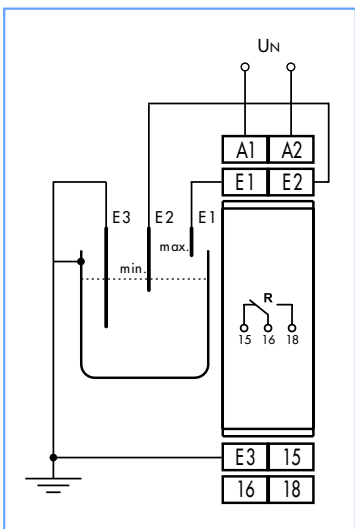

Connecting Diagram

Description

This relay is specified to monitor the fill level of electroconductive liquids with a choice between two functions: Pump Down or Pump Up.

Accessories

Special Heads and Special Rods

Special Head: Material: Nylon, Protection Class: IP65, Thread: 1.5"

Special Rod: Stainless Steel, Epoxy Coating, 900 mm

Optical Output Indicator LED

- Green is lit:** Supply voltage OK
- Green is not lit:** Supply voltage failure
- Yellow is lit:** Relay is energized (contacts 15 and 18 are connected)
- Yellow is not lit:** Contacts 15 and 16 are connected, the level of the measured liquid is above the minimum level (E2) with "PUMP UP", or below the maximum level (E1) with "PUMP DOWN".

Technical Specifications

Description	UR3L1011
Supply Terminals	A1 - A2
Supply Voltage	230 V AC/DC; 50 Hz
Power Consumption	2.5 VA
Supply Voltage Tolerance according to Standard (DIN)	+/- 15%
Monitoring Terminals	E1, E2, E3
Measuring Voltage	Max. $5 V_{ef}/50 \text{ Hz}$
Hysteresis	Adjustable between 5 - 100 k Ω
Max. Electrode Current	< 0,5 mA
Time Delay	5 s fixed setting
Overvoltage Category	III.
Pollution Degree	2
Terminal cross-section with/without Ferrules	2 x 1.5 mm ² ; 2 x 2.5 mm ²
Dimensions	17.6 x 90 x 64 mm
Weight	74 g
Standards	IEC/EN 60255-6
Output	
Schrack Relay Type	RT314024
Number of Changeover Contacts	1
Rated Current/Duty Category	16 A/AC1
Max. Inrush Current	30 A/< 3 s/AC1
Max. Switching Capacity	4000 VA/AC1, 384 W
Min. Permissible Load	DC 500 mW
Output Indicator	Yellow LED
Mechanical Life Expectancy	3 x 10 ⁷ operations
Electrical Life Expectancy at Rated Load	0.7 x 10 ⁵ operations
Surge Withstand	> 3.7 kV
Mounting Position	Any Position

[UR311011 Current Monitor Relay]

28



UR311011

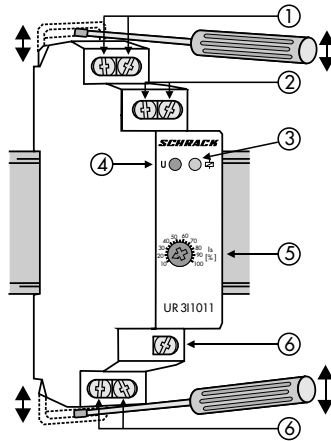

- ① Supply Voltage Terminals
- ② Measuring Terminals
- ③ Output Indicator
- ④ Supply Voltage Indicator
- ⑤ I_s Setting (Switching Point)
- ⑥ Output Contact

Function

This relay monitors current changes in DC and AC circuits. The pick up point is adjustable between 0.5 - 5 A (10-100 % of the rated current) using a potentiometer. Once the supply voltage is applied between terminals A1 and A2 the green LED is lit. If the measured current exceeds the selected pick up level the relay switches to its operational position (connecting contacts 11 and 14) and the yellow LED is lit. If the current falls 10 % below the selected pick up value (hysterisis) the device returns to its idle position (connecting contacts 11 and 12) and the yellow LED is extinguished. The supply circuit and the measuring circuit are electrically isolated.

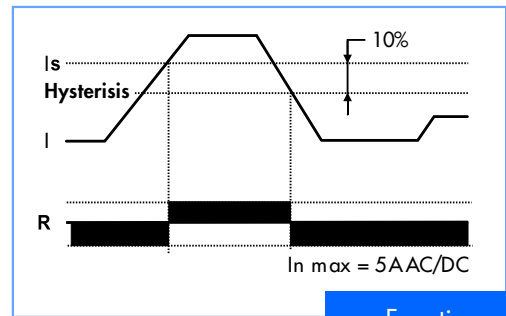

Functions

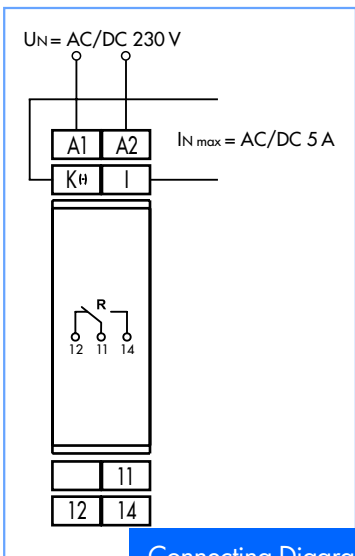

Connecting Diagram

Description

This relay monitors current changes in DC and AC circuits, supply voltage is 230 V AC/DC.

Optical Output Indicator LED

- Green is lit:** Supply voltage OK
- Green is not lit:** Supply voltage failure
- Yellow is lit:** Current is below the switching point, contacts 11 and 14 are connected
- Yellow is not lit:** Contacts in idle state, 11 and 12 are connected

Technical Specifications

Description	UR311011
Supply Terminals	A1 - A2
Supply Voltage	230 V AC/DC;50 Hz
Power Consumption	2,5 VA
Supply Voltage Tolerance according to Standard (DIN)	+/- 15 %
Monitoring Terminals	K(-), I
Effective Range	0.5 - 5 A AC/DC
Setting Accuracy	5% - Mechanical Setting
Repeat Accuracy	1 %
Drop Out Level	10 - 100% of the Rated Current
Hysteresis	10 % fixed
Overvoltage Category	III.
Pollution Degree	2
Terminal Cross-Section with/without Ferrules	2 x 1.5 mm ² ; 2 x 2.5 mm ²
Dimensions	17.6 x 90 x 64 mm
Weight	76 g
Standards	IEC/EN 60255-6
Output	
Schrack Relay Type	RT314024
Number of Changeover Contacts	1
Rated Current /Duty Category	16 A/AC1
Max. Inrush Current	30 A/< 3 s/AC1
Max. Switching Capacity	4000 VA/AC1, 384 W/DC
Min. Permissible Load	DC 500 mW
Output Indicator	Yellow LED
Mechanical Life Expectancy	3 x 10 ⁷ operations
Electrical Life Expectancy at Rated Load	0.7 x 10 ⁵ operations
Surge Withstand	2.5 kV coil to contacts
Mounting Position	Any Position

[UR3P3011 Phase Monitor Relay]



UR3P3011

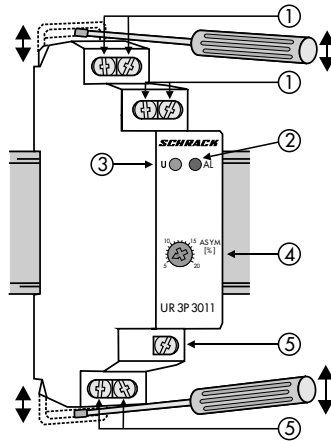

- ① Supply Voltage Terminals
- ② Fault Indicator
- ③ Supply Voltage Indicator
- ④ Unbalance Setting
- ⑤ Output Contact

30

Function

This relay can monitor 3-pole and 4-pole AC circuits for phase loss, incorrect phase sequence and phase unbalance. Once the supply voltage is applied the green LED is lit. If all 3 phases are OK the output relay remains energized (11 and 14 connected). If the selected unbalance value is exceeded, or in case of a change in the phase sequence, the output relay drops back to its idle position (11 and 12 connected) and the red LED is lit. The relay also drops out in case of phase loss. This device has no time delay setting and therefore it reacts instantaneously to failure conditions. Above all, this relay is used to monitor 3-phase motors.

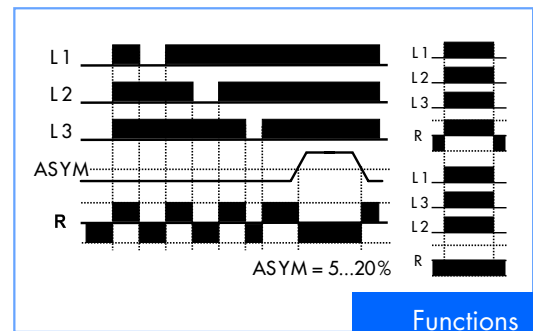

Functions

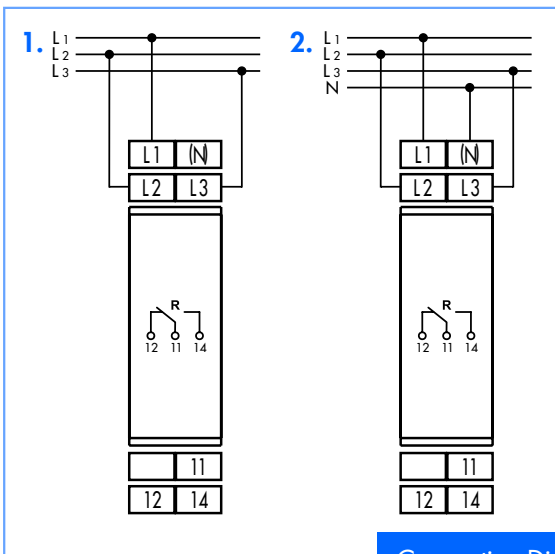

Connecting Diagram

Description

This relay can monitor phases for phase loss, incorrect phase sequence and unbalance. Above all it is used to monitor 3-phase motors.

Max. Monitored Voltage: 276 V AC.

Output Contact: 1 x Changeover Contact 16 A.

1. 3-Pole Connection (without Neutral)
2. 4-Pole Connection (with Neutral)

Optical Output Indicator LED

Green is lit:	Supply voltage OK
Green is not lit:	Supply voltage failure
Red is lit:	Failure condition (unbalance, phase loss or incorrect phase sequence), contacts 11 and 12 are connected.
Red is not lit:	Normal state, contacts 11 and 14 are connected.

Technical Specifications

Description	UR3P3011
Supply and Measuring Terminals	L1, L2, L3, N
Supply and Measuring Voltage	3 x 400 V/230 V AC;50 Hz
Power Consumption	Max. 18 VA
Supply Voltage Indicator	Green LED
Max. Monitored Voltage (vis-à-vis Neutral)	276 V AC
Drop Out Voltage (fixed)	165 V AC
Hysteresis (fixed)	5 %
Unbalance (Adjustable)	5 - 20 %
Overvoltage Category	III.
Pollution Degree	2
Terminal Cross-Section with/without Ferrules	2 x 1.5 mm ² ; 2 x 2.5 mm ²
Dimensions	17.6 x 90 x 64 mm
Weight	80 g
Standards	IEC/EN 60255-6
Output	
Schrack Relay Type	RT314024
Number of Changeover Contacts	1
Rated Current/Duty Category	16 A/AC1
Max. Inrush Current	30 A/< 3 s/AC1
Max. Switching Capacity	4000 VA/AC1, 384 W/DC
Min. Permissible Load	DC 500 mW
Output Indicator	Red LED
Mechanical Life Expectancy	3 x 10 ⁷ operations
Electrical Life Expectancy at Rated Load	0.7 x 10 ⁵ operations
Surge Withstand	2.5 kV coil to contacts
Mounting Position	Any Position

AUSTRIA HEADQUARTERS

SCHRACK ENERGIETECHNIK GmbH
Seybelgasse 13
A-1235 VIENNA
Export Phone +43 1 866 85 520
Export Fax +43 1 866 85 1520
e-mail: export@schrack.com

SCHRACK COMPANIES

BELGIUM

SCHRACK ENERGIETECHNIK B.V.B.A.
Twaalfpostelenstraat 14
B-9051 SINT-DENIJS-WESTREM
Phone +32 9 384 79 92
Fax +32 9 384 87 69
e-mail: info@schrack.be

CROATIA

SCHRACK ENERGIETECHNIK d.o.o.
Zavrtnica 17
HR-10000 ZAGREB
Phone +385 1 605 55 00
Fax +385 1 605 55 66
e-mail: schrack@schrack.hr

CZECH REPUBLIC

SCHRACK ENERGIETECHNIK spol.sr.o.
Dolnomecholupska 2
CZ-10200 PRAHA 10 – Hostivar
Phone +420 2 810 08 264
Fax +420 2 810 08 462
e-mail: praha@schrack.cz

HUNGARY

SCHRACK ENERGIETECHNIK Kft.
Vidor u.
H-1172 BUDAPEST
Phone +36 1 253 14 01
Fax +36 1 253 14 91
e-mail: schrack@schrack.hu

POLAND

SCHRACK ENERGIETECHNIK
POLSKA sp.z.o.o.
ul. Annapol 3
PL-03236 WARSZAWA
Phone +48 22 331 48 31
Fax +48 22 331 48 33
e-mail: se@schrack.pl

ROMANIA

SCHRACK ENERGIETECHNIK Srl
Str. Simion Barnutiu nr. 15
RO-3700 ORADEA
Phone +40 59 435 887
Fax +40 59 412 892
e-mail: schrack@schrack.ro

SERBIA-MONTENEGRO

SCHRACK ENERGIETECHNIK d.o.o.
Kumodraska 260
YU-11000 BEOGRAD
Phone +381 11 309 6056
Fax +381 11 309 6056
e-mail: schrakom@verat.net

SLOVAC REPUBLIC

SCHRACK ENERGIETECHNIK spol.sr.o.
Langsfeldova 2
SK-03601 MARTIN
Phone +421 43 422 16 413
Fax +421 43 423 95 56
e-mail: se-martin@schrack.sk

SLOVENIA

SCHRACK ENERGIETECHNIK d.o.o.
Glavni trg 47
SLO-2380 SLOVENJ GRADEC
Phone +386 2 883 92 00
Fax +386 2 884 34 71
e-mail: schrack.sg@schrack-energietechnik.si

DISTRIBUTORS EUROPE

BOSNIA-HERZEGOVINA

ELECTRICA d.o.o.
Kralja P. Kresimira IV. 13a
BIH-88000 MOSTAR
Phone +387 36 333 666
Fax +387 36 333 667
e-mail: electrica@mo.pincom.net

BULGARIA

WEID-BUL
ul. Nezabavka 33a
BG-1113 SOFIA
Phone +359 2 963 25 60
Fax +359 2 963 10 98
e-mail: weidbul@nat.bg

GREAT BRITAIN

A.P. HASLAM (SCOTLAND) LTD.
3 Forties Gateway
Rosyth Europarc
Rosyth, Fife KY11 2WP/Scotland
Phone +44 1383 428 900
Fax +44 1383 428 998
e-mail: salesscotland@aphaslam.com

TPD (UK) LTD.

Unit 19, Chamberlayne Road,
Moreton Hall Industrial Estate,
Bury St. Edmunds, Suffolk. IP32 7EY
Phone +44 1284 769 260
Fax +44 1284 765 599
e-mail: tpd01@globalnet.co.uk

ICELAND

RAFPORT ehf
Nybylavegur 14
IS-200 KAPAVAGUR
Phone +354 554 4443
Fax +354 554 4102
e-mail: rafport@rafport.is

IRELAND

A.P. HASLAM LTD.
14 Sunshine Industrial Estate,
Crumlin Road,
Dublin 12
Phone +353 1 453 2522
Fax +353 1 453 2949
e-mail: sales@aphaslam.ie

ITALY

ELETTRO-RINNOVABILE di. A. JANK
Via delle Miniere
I-33030 MARLBORHETTO-Valbruna
Phone +39 04 28 41 911
Fax +39 04 28 41 911

SIEI PETERLONGO S.p.A.

Via Carducci 24
I-21040 GERANZANO
Phone +39 02 967 601
Fax +39 02 968 2653
e-mail: sieipt@siei.it

LATVIA

JUMIKS ENERGETEHNKA
A. Deglava street 166A
LV-1021 RIGA
Phone +371 7 80 01 88
Fax +371 7 80 01 96
e-mail: info@jumiksenergetehnika.lv

DISTRIBUTORS OVERSEAS

BAHRAIN

MERIAM FACTORIES & EST.
P.O. Box 21118
MANAMA – BAHRAIN
Phone +973 8 74222
Fax +973 8 74221
e-mail: mrabia@batelco.com.bh

AL ANWAR FACTORY WLL
South Alba Industrial Area, Askar,
P.O. Box 37852 or 948
MANAMA - BAHRAIN
Phone +973 8 30553
Fax +973 8 30595

CYPRUS

P.G.S. ELECTRICAL SUPPLIES Ltd
150, 1st April Avenue
P.O. Box 33088
5310 PARALIMNI
Phone +357 23 822 022
Fax +357 23 820 010

HONG KONG

CREATION BUILDING SERVICES
MATERIALS LIMITED
14/F Hing Yip Centre
37 Beech Street, Tai Kok Tsui
HONG KONG, Kowloon
Phone +85 2 2398 2106
Fax +85 2 2398 5808
e-mail: yshit@netvigator.com

MIDDLE EAST

JORDAN/KUWAIT/OMAN/ QATAR/SAUDI ARABIA/UAE:

CDME MIDDLE EAST LTD.
P.O. Box 25491
CY-1310 NICOSIA - CYPRUS
Phone +357 2 672 577 (7 lines)
Fax +357 2 678 065
e-mail: dina@cdme.com.cy

SYRIA

NOUWEILATI & HAMWI CO.
P.O. Box 1359
DAMASCUS – SYRIA
Phone +963 11 221 15 89
Fax +963 11 224 63 66
e-mail: n.h.co@net.sy

TAIWAN

HONEXTRIC ELECTRIC CO.LTD
Add. 2F, No. 43, CHUNG TE ST,
Taipei 110, TAIWAN R.O.C.
Phone +886 2 273 712 31
Fax +886 2 273 366 43
e-mail: honex@ms3.hinet.net

UNITED ARAB EMIRATES

ABDULLA HASSAN SWITCHGEAR
INDUSTRY L.L.C
P.O. Box 51610, DUBAI
Phone +971 4 2673797
Fax +971 4 2673139

ADVANCED TECHNOLOGY &
POWER INDUSTRIES
P.O. Box 778, DUBAI
Phone +971 4 2276744
Fax +971 4 2279708

JUMA AL MAJID EST.
P.O. Box 60204, DUBAI
Phone +971 4 2854225
Fax +971 4 2854678

SAFETY ELECTRICAL TRADING CO.
P.O. Box 3494
Phone +971 4 2666410
Fax +971 4 2697862

SCHRACK